

1

2

3

4

MARK

REVISER

DESCRIPTRN

DATE

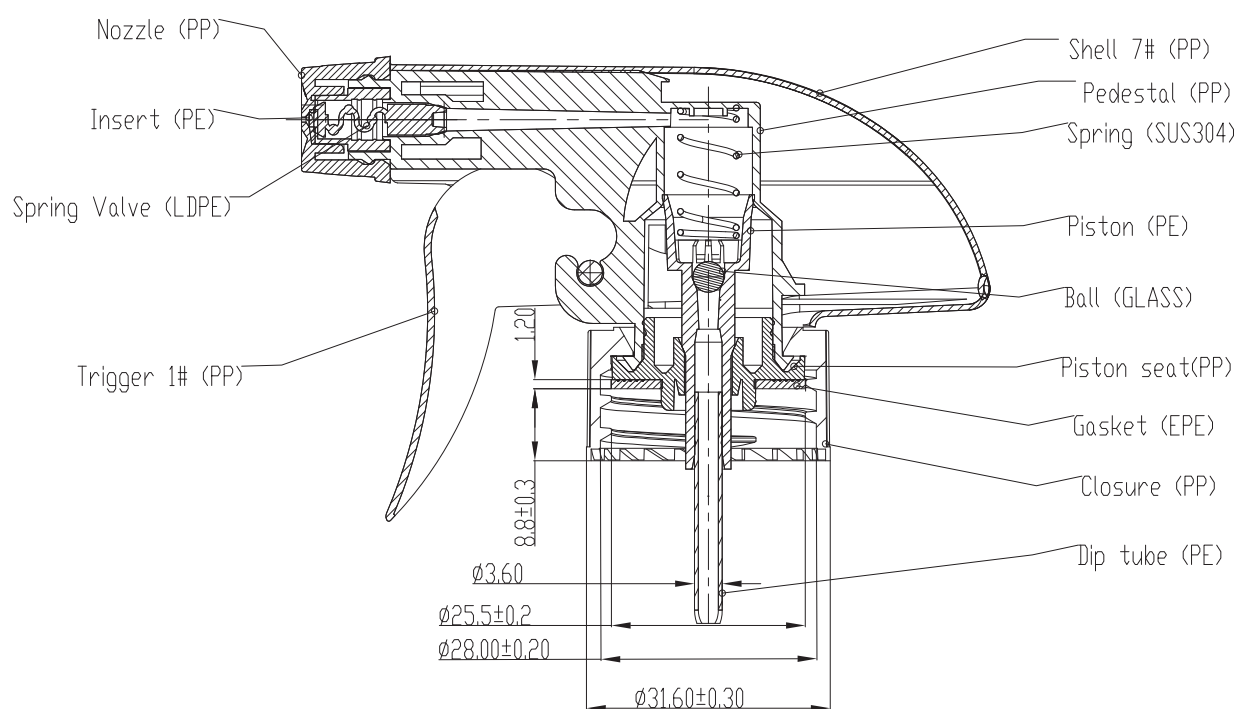

NOTE:
1.DOSAGE:0.75±0.1ml/T

TOLERANCE			
0mm-15mm	±0.05	±0.10	±0.50
15mm-30mm	±0.05	±0.15	±1.00
30mm-50mm	±0.10	±0.20	±1.50
50mm-99mm	±0.15	±0.30	±2.00
ABOVE 99mm	±0.20	±0.40	±2.50
CENTER	±0.10	±0.50	±1.00
ANGLER	±0.25°	±0.50°	±2.00°

DRAFTER:

UNIT: mm

SCALE:

CHECKED:

MODEL NAME:

TITLE:

28/400 spray/stream

CENSOR:

MATERIAL:

VISUAL ANGLE

Q'TY:

REV:



1/1

A0

APPROVED:

PART NO:

FILE NO:

021

D-

1

2

3

4